

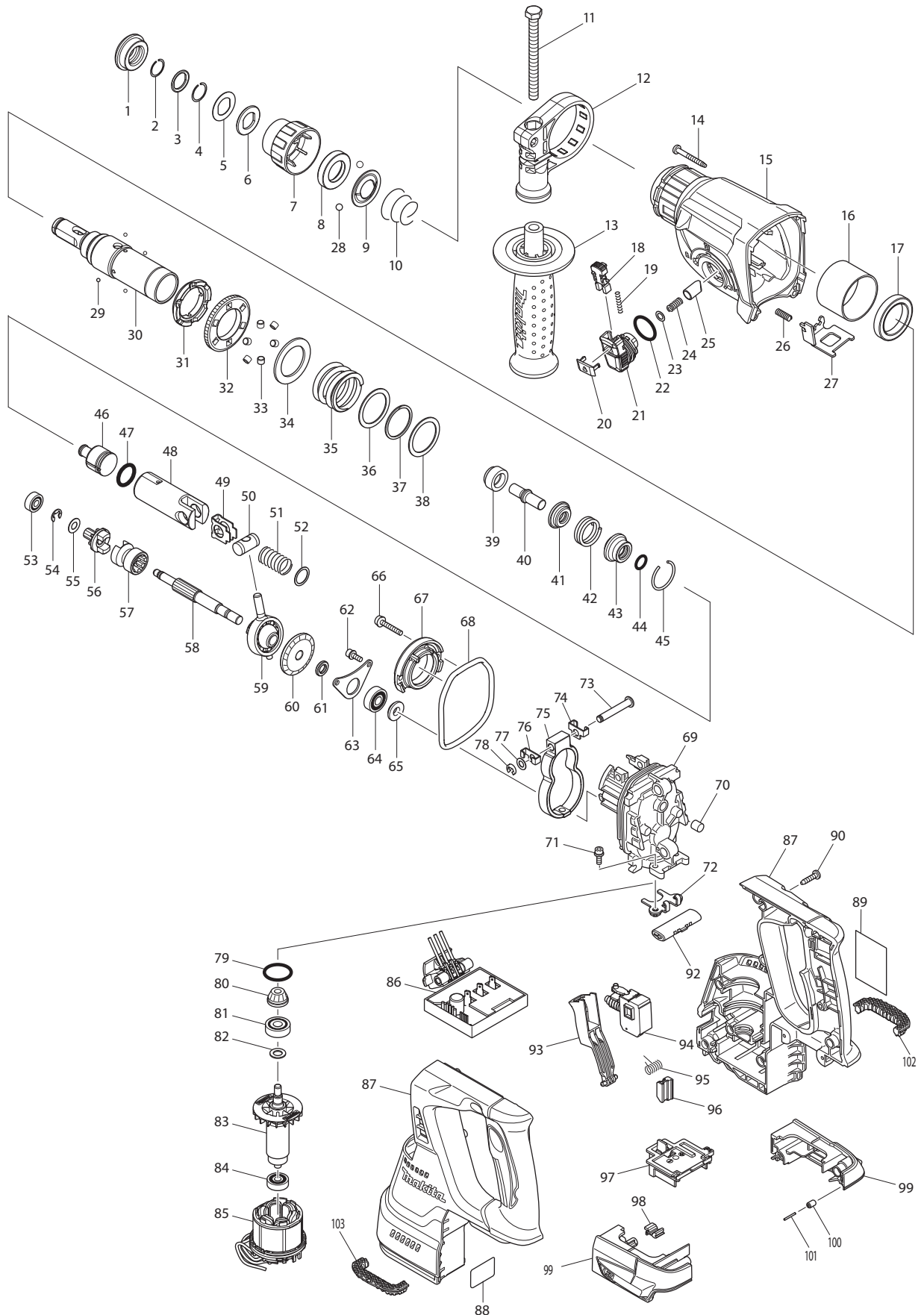

01 - 2015  
DHR242RFEV, DHR242RMEV, DHR242ZVX  
18V BRUSHLESS ROTARY HAMMER  
(SDS-PLUS, 3 MODE)



Item No	Type	Sub	Part No	Description	Qty	Unit
001			286288-8	CAP 35	1	PC.
002			233989-9	RING SPRING 14	1	PC.
003			346221-3	WASHER 16	1	PC.
004			233992-0	RING SPRING 15	1	PC.
005			267437-6	FLAT WASHER 17	1	PC.
006			424364-2	RUBBER WASHER 16	1	PC.
007			451533-2	CHUCK COVER	1	PC.
008			325813-1	RING 21	1	PC.
009			346177-0	GUIDE WASHER	1	PC.
010			233916-6	CONICAL COMP. SPRING 21-29	1	PC.
011			266745-2	HEX.BOLT M8X90	1	PC.
012			453129-5	GRIP BASE	1	PC.
013			158057-6	GRIP 36 COMPLETE	1	PC.
014			266351-3	TAPPING SCREW 4X35	4	PC.
015			141229-0	GEAR HOUSING COMPLETE	1	PC.
		INC.	213345-9	OIL SEAL 25	1	PC.
		INC.	890903-4	INDICATION LABEL	1	PC.
016			331890-3	CUP SLEEVE	1	PC.
017			211294-4	BALL BEARING 6806LLU	1	PC.
018			454112-5	LOCK BUTTON	1	PC.
019			234264-6	COMPRESSION SPRING 3	1	PC.
020			453131-8	CHANGE LEVER COVER	1	PC.
021			453125-3	CHANGE LEVER	1	PC.
022			213381-5	O RING 21	1	PC.
023			253308-3	THIN WASHER 6	1	PC.
024			234147-0	COMPRESSION SPRING 5	1	PC.
025	2		326850-8	* PUSH CORN	1	PC.
026			233360-7	COMPRESSION SPRING 4	1	PC.
027			346537-6	LOCK PLATE	1	PC.
028			216022-2	STEEL BALL 7.0	2	PC.
029			216019-1	STEEL BALL 3	4	PC.
030			140265-3	TOOL HOLDER COMPLETE	1	PC.
031	2		332139-4	* DRIVING FLANGE	1	PC.
032	2		227360-7	* SPUR GEAR 51	1	PC.
035			234148-8	COMPRESSION SPRING 31	1	PC.
036			267153-0	FLAT WASHER 30	1	PC.
037			257932-4	SPIRO LOCK WASHER 30	1	PC.
038			267153-0	FLAT WASHER 30	1	PC.
039			325783-4	SLEEVE 9B	1	PC.
040			325789-2	IMPACT BOLT A	1	PC.
041			325792-3	WASHER 10	1	PC.
042			234149-6	COMPRESSION SPRING 20	1	PC.
043			325793-1	O-RING CASE B	1	PC.
044			213073-6	O RING 9	1	PC.
045			233979-2	RING SPRING 28	1	PC.
046			326139-4	STRIKER	1	PC.
047			213258-4	O RING 17.5	1	PC.
048			310345-1	PISTON CYLINDER	1	PC.
049			346036-8	GUIDE PLATE	1	PC.
050			324215-8	PISTON JOINT	1	PC.
051			234098-7	COMPRESSION SPRING 14	1	PC.
052			267447-3	FLAT WASHER 14	1	PC.
053			211012-0	BALL BEARING 606ZZ	1	PC.
054			257336-0	STOP RING EXT U-6	1	PC.
055			253186-1	FLAT WASHER 7	1	PC.

Item No	Type	Sub	Part No	Description	Qty	Unit
056			227231-8	SPUR GEAR 10	1	PC.
057	2		326849-3	* CLUTCH CAM A	1	PC.
058			326140-9	CAM SHAFT	1	PC.
059			219020-5	SWASH BEARING 10	1	PC.
060			227588-7	SPIRAL BEVEL GEAR 32	1	PC.
061			257323-9	RING 8	1	PC.
062			922118-6	HEX. SOCKET HEAD BOLT M4X12	2	PC.
063			346038-4	BEARING RETAINER B	1	PC.
064			211032-4	BALL BEARING 608ZZ	1	PC.
065			324212-4	RING 8	1	PC.
066			922147-9	HEX. SOCKET HEAD BOLT M4X25	2	PC.
067			141230-5	INNER SUPPORT COMPLETE	1	PC.
068			213767-3	O-RING 75	1	PC.
069			318810-4	INNER HOUSING	1	PC.
070			443153-6	FELT	1	PC.
071			922118-6	HEX. SOCKET HEAD BOLT M4X12	2	PC.
072			346536-8	BEARING RETAINER A	1	PC.
073			256536-9	FLAT FILLISTER HD PIN 6	1	PC.
074			346538-4	WEIGHT HOLDER GUIDE	1	PC.
075			313224-2	COUNTER WEIGHT	1	PC.
076			346538-4	WEIGHT HOLDER GUIDE	1	PC.
077			253726-5	FLAT WASHER 6	1	PC.
078			961018-5	STOP RING E-5	1	PC.
079			213008-7	O RING 22.4	1	PC.
080			141458-5	* SPIRAL BEVEL GEAR 11 COMPLETE	1	PC.
081			210024-0	* BALL BEARING 608LLU	1	PC.
082			253835-0	* FLAT WASHER 8	1	PC.
083	1		619293-4	* ROTOR	1	PC.
	2		619737-4	* ROTOR	1	PC.
		INC.		* Item No. 80-82, 84	1	PC.
084			210022-4	* BALL BEARING 626DDW	1	PC.
085	3		529187-4	* STATOR ASSY	1	PC.
086	1		620241-8	* CONTROLLER	1	PC.
	2		620G68-8	* CONTROLLER	1	PC.
087	3		183C04-6	* HOUSING SET	1	SET
		INC.	802L43-8	* CAUTION LABEL FR/SP	1	PC.
088			815B57-8	DHR242 SERIAL NO. LABEL	1	PC.
089			815A38-6	NAME PLATE F/DHR242	1	PC.
090			266326-2	TAPPING SCREW 4X18	10	PC.
092			453124-5	F/R CHANGE LEVER	1	PC.
093			453123-7	SWITCH LEVER	1	PC.
094			650709-0	SWITCH C3JW-1A-P	1	PC.
095			233598-4	TORSION SPRING 6	1	PC.
096			313226-8	OPENER	1	PC.
097			644808-8	TERMINAL	1	PC.
098			424476-1	CUSHION	1	PC.
099			187377-1	BATTERY HOUSING SET	1	PC.
		INC.	263005-3	RUBBER PIN 6	2	PC.
100			263036-2	RUBBER PIN 5	1	PC.
101			268184-2	PIN 1.5	1	PC.
102			424473-7	CUSHION RUBBER	1	PC.
103			424473-7	CUSHION RUBBER	1	PC.
105			893072-0	CLEAR LABEL	1	PC.
107			424734-5	* SPONGE (Added)	1	PC.
D01			654281-4	RECEPTACLE	3	PC.

Item No	Type	Sub	Part No	Description	Qty	Unit
<b>ACCESSORIES</b>				<b>- See Catalogue or visit <a href="http://www.makita.ca">www.makita.ca</a> for more accessories -</b>		
A01			324219-0	DEPTH GAUGE	1	PC.
A02			---	BATTERY CHARGER		
A03			---	18V LI-ION BATTERY		
A04			---	LI-ION BATTERY ACCESSORIES		
A05A	2		140H96-8	PLASTIC CARRYING CASE F/ DHR242RFEV, DHR242RMEV	1	PC.
		INC.	162271-8	LATCH	2	PC.
		INC.	890904-2	INDICATION LABEL (PICTURE)	1	PC.
A05B	2		821007X	TOOL BAG	1	PC.
A05C			197213-3	INTERLOCKING CASE XL	1	PC.
		INC.	453974-8	LOCKING LATCH	4	PC.
A07			DX06	DUST EXTRACTION SYSTEM	1	PC.
	2	INC.	422784-4	SEALING CAP	5	PC.
A09			122574-2	1/2" DRILL CHUCK ATTACHMENT, SDS-PLUS	1	PC.
		INC.	192877-8	1/2" DRILL CHUCK	1	PC.
		INC.	751106-4	CHUCK ADAPTOR SDS-PLUS	1	PC.
		INC.	251425-3	- FLAT HEAD SCREW M6X22	1	PC.
A10			122823-7	KEYLESS DRILL CHUCK	1	PC.
		INC.	192892-2	KEYLESS DRILL CHUCK	1	PC.
		INC.	751106-4	CHUCK ADAPTOR SDS-PLUS	1	PC.
		INC.	251425-3	- FLAT HEAD SCREW M6X22	1	PC.
A11			D-14093	CHUCK ADAPTER ASSY (SDS-PLUS)	1	PC.
		INC.	751106-4	CHUCK ADAPTOR SDS-PLUS	1	PC.
		INC.	251425-3	- FLAT HEAD SCREW M6X22	1	PC.
A12			763432-9	CHUCK KEY S13, LONGER HANDLE	1	PC.
			798341-3	CHUCK KEY S13, SHORTER HANDLE	1	PC.
A13			191686-2	SAFETY GOGGLE	1	PC.
A14			194683-7	GREASE VESSEL SET, 100CC	1	PC.
A15			195048-6	DUSTCUP SET (North America Package)	1	PC.
		INC.	213310-8	O RING 20	1	PC.
		INC.	424268-8	CAP 39	1	PC.
		INC.	424269-6	DUST CAP	1	PC.
		INC.	451541-3	BELLOWS	1	PC.
		INC.	451542-1	ATTACHMENT	1	PC.
		INC.	451543-9	JOINT	1	PC.
A16			421342-3	DUST CUP 5	1	PC.
			421664-1	DUST CUP 9	1	PC.
A20			765009-6	BLOW-OUT BULB 64	1	PC.
A21	2		195548-6	JOINT 22-38	1	PC.
A22			195833-7	HAMMER SERVICE KIT	1	PC.
		INC.	233992-0	RING SPRING 15	1	PC.
		INC.	424364-2	RUBBER WASHER 16	1	PC.
		INC.	233989-9	RING SRPING 14	1	PC.
		INC.	286288-8	CAP 35	1	PC.
		INC.	233979-2	RING SRPING 28	1	PC.
		INC.	216022-2	STEEL BALL 7.0	2	PC.
		INC.	213258-4	O-RING 17.5	1	PC.
		INC.	213073-6	O-RING 9	1	PC.
		INC.	195127-0	MAKITA GREASE RB NO. 00, 30G	2	PC.
A23	2		199588-6	DUST CASE SET	1	PC.
		INC.	196164-7	HEPA FILTER SET	1	PC.
		INC.	453150-4	FILTER COVER	1	PC.

**SERVICE CHANGES**

**1. Changes on Housing Set & Stator**

( TI#Y07053, A6091 )

( TI#A9880 )

Item No.	Description	Type 1	Type 2	Type 3
85	Stator > Startor Assy	629922-1	529922-0	529187-4
87	Housing Set	187767-8	183A40-0	183C04-6
INC.	Caution Label FR/SP		802L43-8	
107	Sponge	-----	-----	424734-5

Type 2 and Type 3 parts are completely interchangeable as a set.

Left: Type 1

Right : Type 2

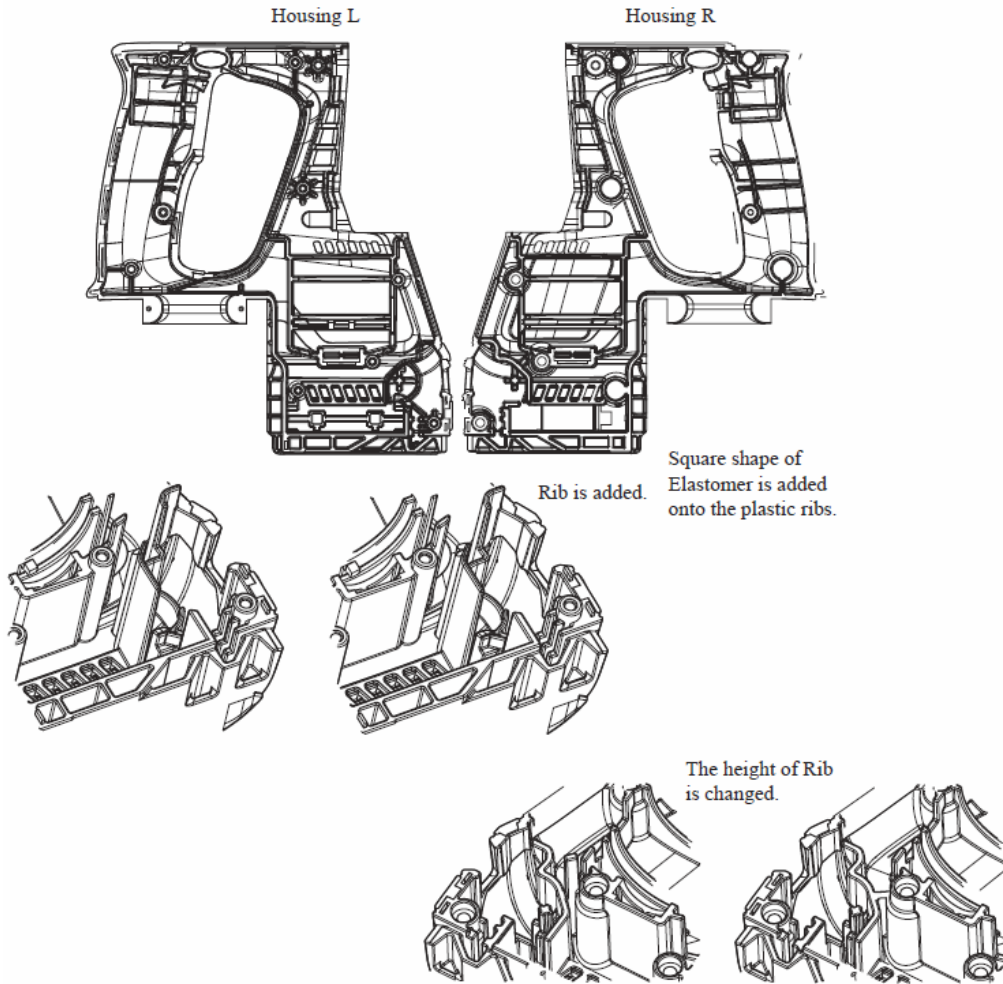

No. 85 Type 2 ~

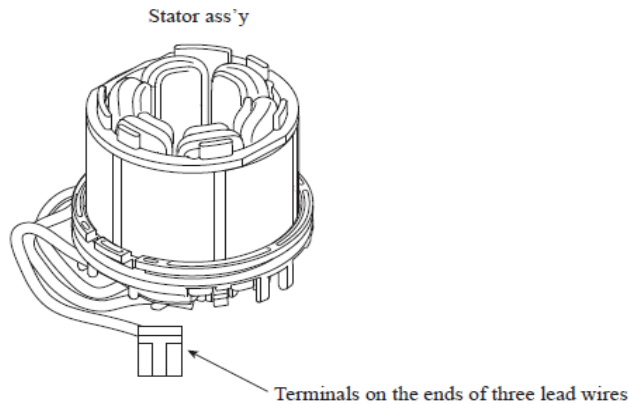

**2. Changes on Spur gear 51 and Driving flange**

( TI#A6980 )

Item No.	Description	Type 1	Type 2
32	Spur Gear 51	227232-6	227360-7
31	Driving Flange	313149-0	332139-4
34	Flat Washer 30	267414-8	-----
33	Pin 6	268226-2	-----

Above parts are completely interchangeable as a set.  
From January 2015 Production

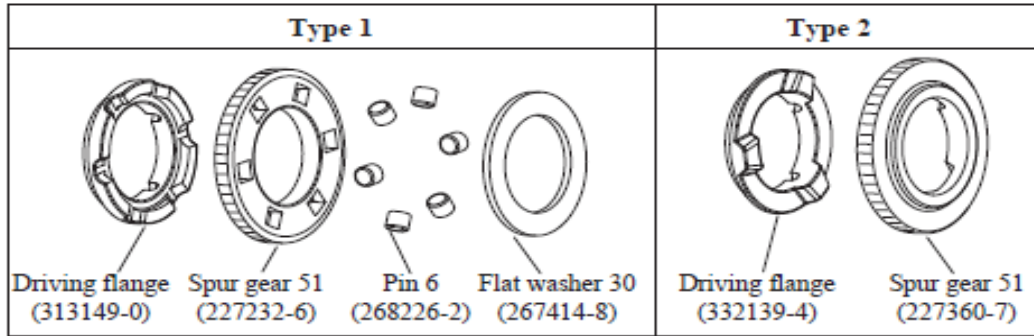

**3. Changes on Clutch cam A and Push corn**

( TI#B4855 )

Item No.	Description	Type 1	Type 2
25	Push Corn	325785-0	326850-8
57	Clutch Cam A	331814-9	326849-3

Above parts are completely interchangeable as a set.

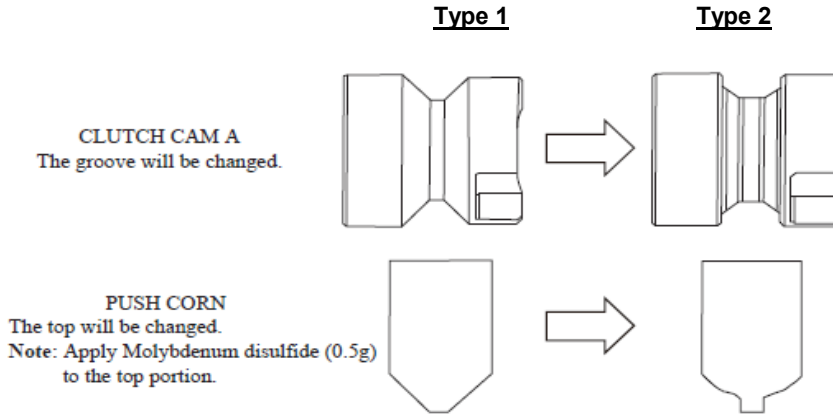

**4. Changes on Controller and Rotor**

( TI#DL611\_DG312 )

Item No.	Description	Type 1	Type 2
86	Controller	620241-8	620G68-8
83	Rotor	619293-4*	619737-4*
80	SPIRAL BEVEL GEAR 11 COM.	-----	141458-5
81	BALL BEARING 608LLU	-----	210024-0
82	FLAT WASHER 8	-----	253835-0
84	BALL BEARING 626DDW	-----	210022-4

Components of  
Item No. 83  
(Type 2)

Above parts are completely interchangeable as a set.

\*In case of repairing the machine with SPM Rotor (619293-4), use the current Controller (620241-8).  
The current Controller for countries subject to standards (See page 2.) cannot be used for the products manufactured after February 2023. See T/I#DL611

		Compatibility of Combination	
		620241-8	620G68-8

		(Current Controller)	(New Controller)
Rotor in the machine	SPM Rotor (619293-4)	Yes	No
	IPM Rotor (619737-4)	Yes	Yes